

Technical Data

Split Frame

Tech 203

Material 16 Gauge (0.053 min) (Typical)
Gauge 14 Gauge (0.067 min)

Material Type Cold Rolled Steel - ASTM A1008
 A60 Galvannealed - ASTM A653
 G90 Galvanized - ASTM A653 (not recommended)

Fire Rating Up To 90 minutes
 4'-0" x 8'-0" Max



Welding Options Full Profile Welded (Continuous Welded)

Anchoring Options #8 Screws (by others) & 1/4" Screws (by others)

Wall Types Drywall (Typical)

Profile Types Equal Rabbet (Standard)
 Un-Equal Rabbet
 Single Rabbet

Warranty One Year (365 days) from the date of delivery

Additional Notes Attachment screws by others
 Fits Tightly Around Pre-Framed Wood or Metal Stud Walls
 Rough Opening to be 1/2" to 5/8" greater than door in each direction
 Width Add 1" to 1-1/4" overall to door width
 Height Add 1/2" to 5/8" overall to door height

Reinforcements	Hinge	7 Gauge (0.167 min)
	4 7/8" Strike	11 Gauge (0.108 min)
	Flush Bolts	11 Gauge (0.108 min)
	Surface Bolts	12 Gauge (0.093 min)
	Surface Closer	12 Gauge (0.093 min)
	Surface Holder/Stop	12 Gauge (0.093 min)
	Surface Applied Strike	12 Gauge (0.093 min)
	Pivots	7 Gauge (0.167 min)

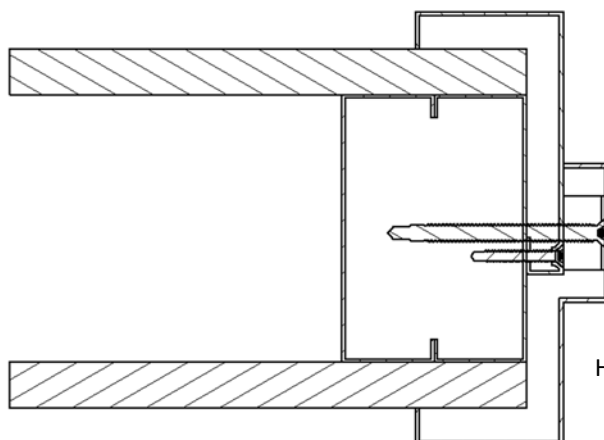
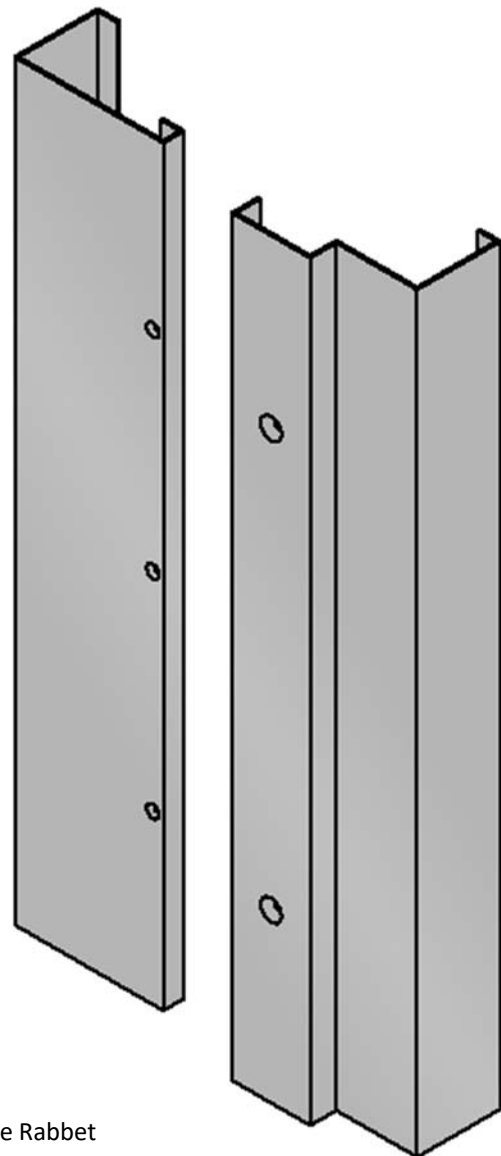

Hardware Rabbet